

## TAILGATER GRILL & GRIDDLE COMBO

COMBO DE PARRILLA Y PLANCHA PARA PARRILLADAS AL AIRE LIBRE

GRIL DE CHAUFFAGE & PLAQUE DE CUISSON COMBO

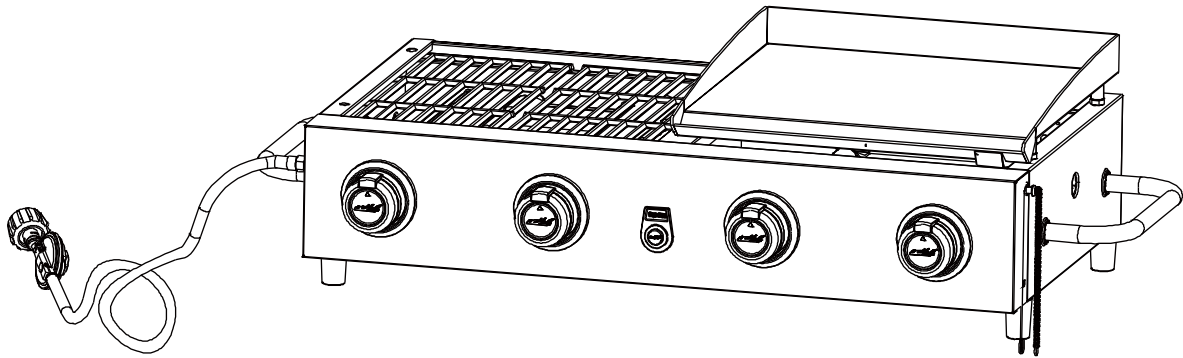

### FOR YOUR SAFETY! | ¡PARA SU SEGURIDAD! | POUR VOTRE SÉCURITÉ!

Use outdoors only!  
Read the instructions before  
assembling and using the appliance.

¡Solo usa al aire libre!  
Lea las instrucciones antes  
de montar y utilizar el aparato.

Utilisez uniquement à l'extérieur!  
Lisez les instructions avant  
d'assembler et d'utiliser l'appareil.

### CONTACT US FIRST! | ¡PÓNGASE EN CONTACTO CON NOSOTROS PRIMERO! | CONTACTEZ-NOUS D'ABORD!

If you have any questions that are  
not addressed, please contact us first.

Si tiene alguna pregunta que no se  
aborde en este Manual del Usuario,  
póngase en contacto con nosotros primero.

Si vous avez des questions qui ne  
sont pas traitées dans ce manuel de  
l'utilisateur, contactez-nous d'abord.



Customer Service / Servicio al Cliente / Service de Clientèle



1-800-618-6798



service@royalgourmetusa.com



Learn more at / Obtener más información en / Pour en savoir plus:

[www.royalgourmetcorp.com](http://www.royalgourmetcorp.com)

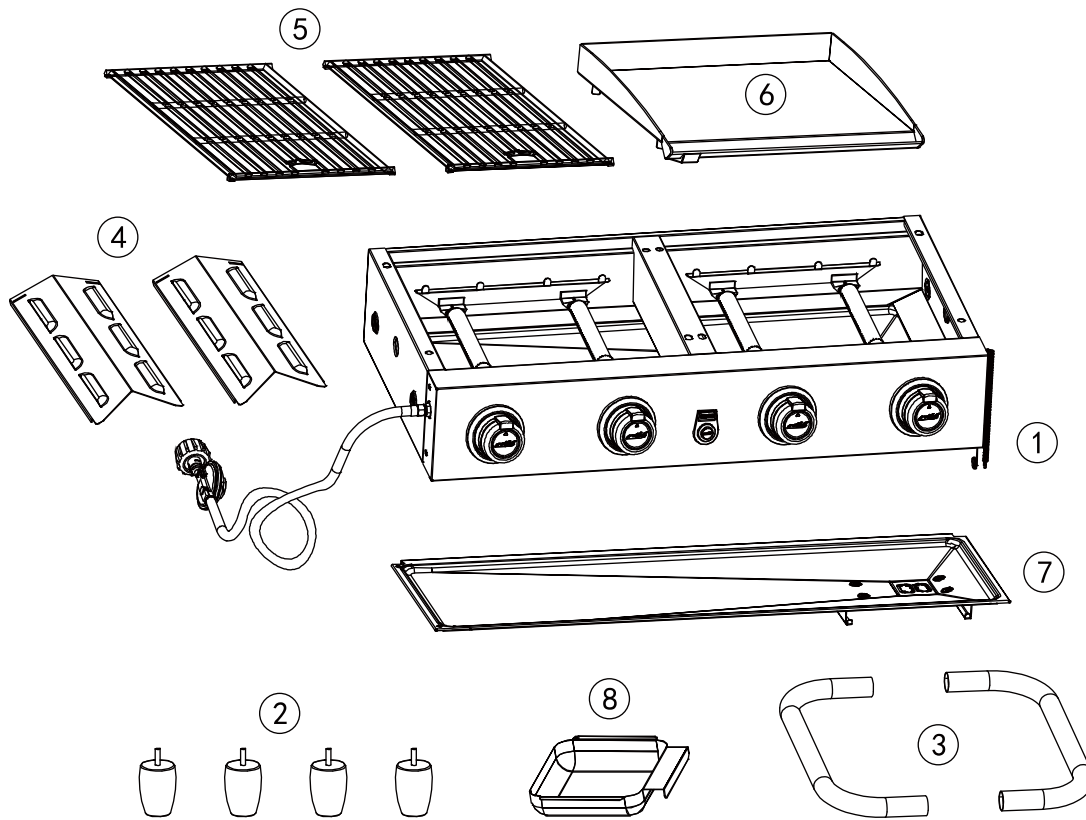

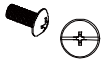

No.	#	QYT / CANT. / QTÉ	Description / Descripción / Description	Image / Imagen / l' image
1		1	Main body Cuerpo principal Corps principal	
2	W-10030015	4	Leg base Base de pata Base de pied	
3	W-GD4002T005	2	Side handle Tirador lateral Poignée d'appoint	
4	Z-GD4002T016	2	Flame tamer Regulador de llama Atténuateur de flamme	
5	W-GD4002T002	2	Cooking grate Rejilla para asar Grille de cuisson	
6	H-GD4002T002	1	Cooking griddle Plancha superior Plaque de cuisson	
7	ALTJYP5B	1	Grease tray Bandeja de recogida de grasa Lèche-frite	
8	Z-GD800109	1	Grease cup Recipiente de recogida de grasas Bac à graisse	

Key / Clave / Réf.	Description / Descripción / Description	QTY / CANT. / QTÉ	Image / Imagen / l' image
A	M6x15	4	
B	Stud with nut Espárrago con tuerca integrada Goujon avec écrou	4	

TOOLS REQUIRED / HERRAMIENTAS REQUERIDAS / OUTILS REQUIS	
Description / Descripción / Description	Image / Imagen / Image
Phillips screwdriver Destornillador phillips Tournevis phillips	

Before beginning assembly, make sure all parts are present. If any parts are missing or damaged, do not attempt to assemble the products. Contact customer service for replacement parts via telephone or email.

- Tools needed (not included): Phillips screwdriver
- Approximate assembly time: 10 minutes
- Note: Model shown for illustration purpose only, specific please in kind prevail.

Antes de comenzar el montaje, asegúrese de que todas las piezas estén presentes. Si falta alguna pieza o está dañada, no intente ensamblar los productos. Póngase en contacto con el servicio de atención al cliente para obtener piezas de repuesto por teléfono o correo electrónico.

- Herramienta necesaria (no incluido): Destornillador phillips
- Tiempo aproximado de ensamblaje: 10 minutos
- Nota: El modelo que se muestra es sólo para fines ilustrativos, prevalecen los específicos en especie.

Avant de commencer l'assemblage, assurez-vous que toutes les pièces sont présentes. Si des pièces sont manquantes ou endommagées, n'essayez pas d'assembler les produits. Contactez le service de clientèle pour les pièces de rechange par téléphone ou par e-mail.

- Outils nécessaires (non inclus): Tournevis phillips
- Temps nécessaire pour l'assemblage: 10 minutes
- Remarque: Le modèle est présenté à des fins d'illustration uniquement, spécifiques en nature prévalent.

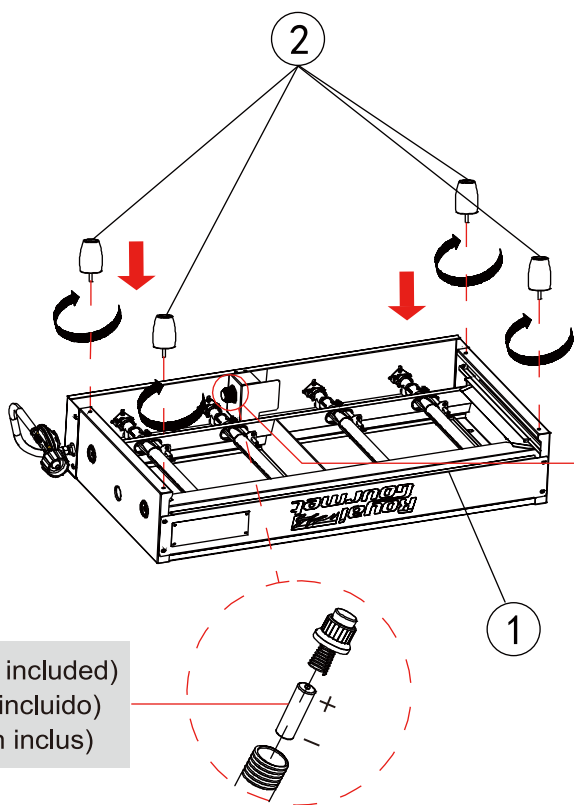

1



- Unscrew cap and install battery.
- Desenrosque la tapa e instale la pila.
- Dévissez le capuchon et installez le pile.

- (Not included)
- (No incluido)
- (Non inclus)

2

A			x2
---	---	---	----

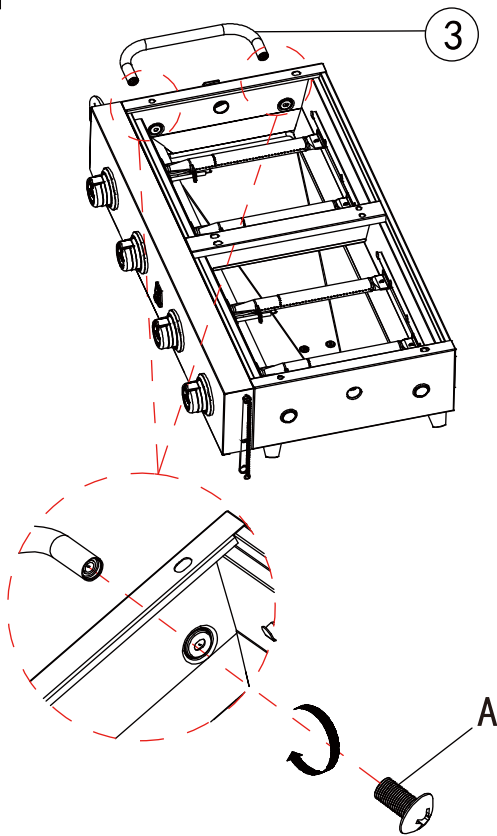

3 A  ×2

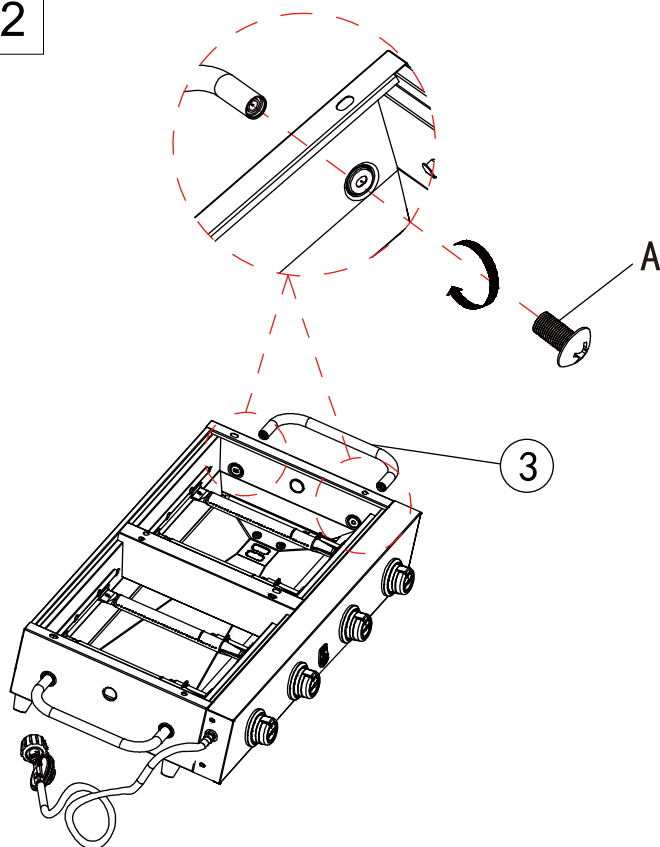

4

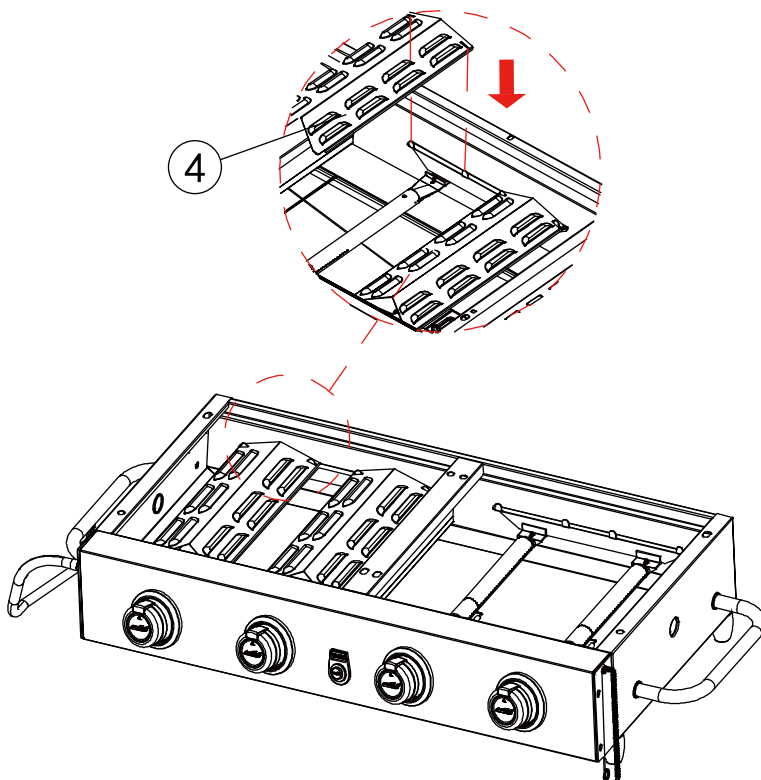

5

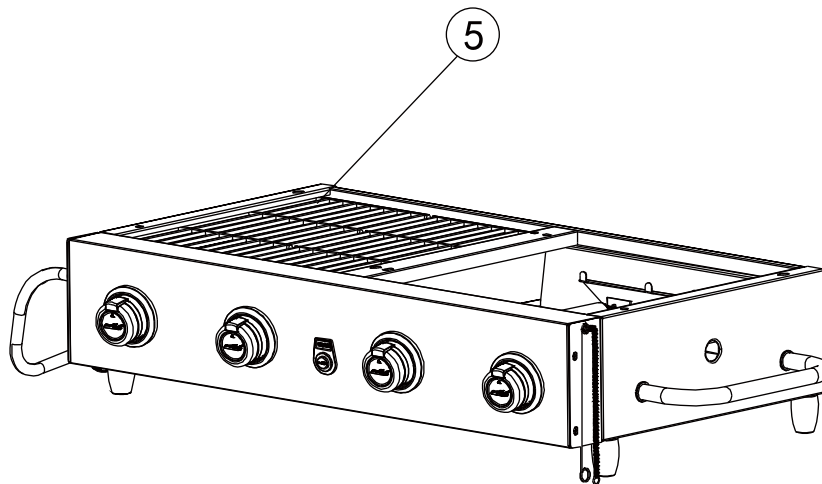

6 B  ×4

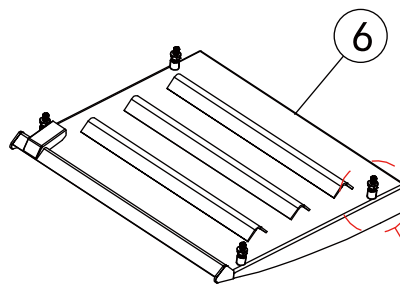

- Adjust nuts to ensure the flatness of griddle.
- Ajustar las tuercas asegurando la planitud de la plancha.
- Ajustez les écrous pour assurer la planéité de la plaque.

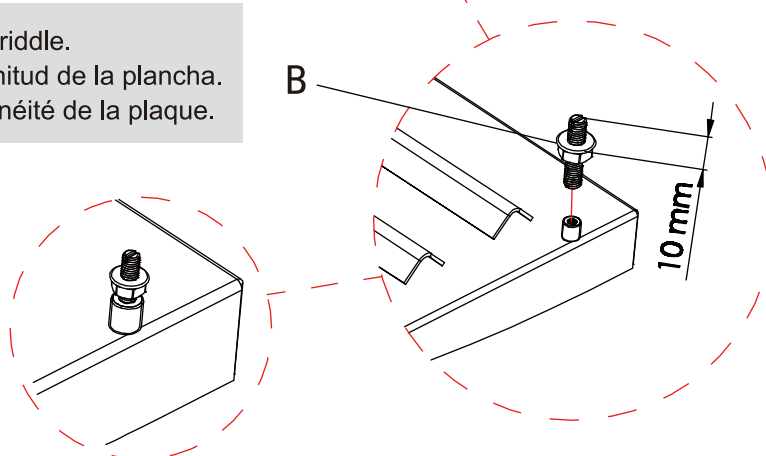

7

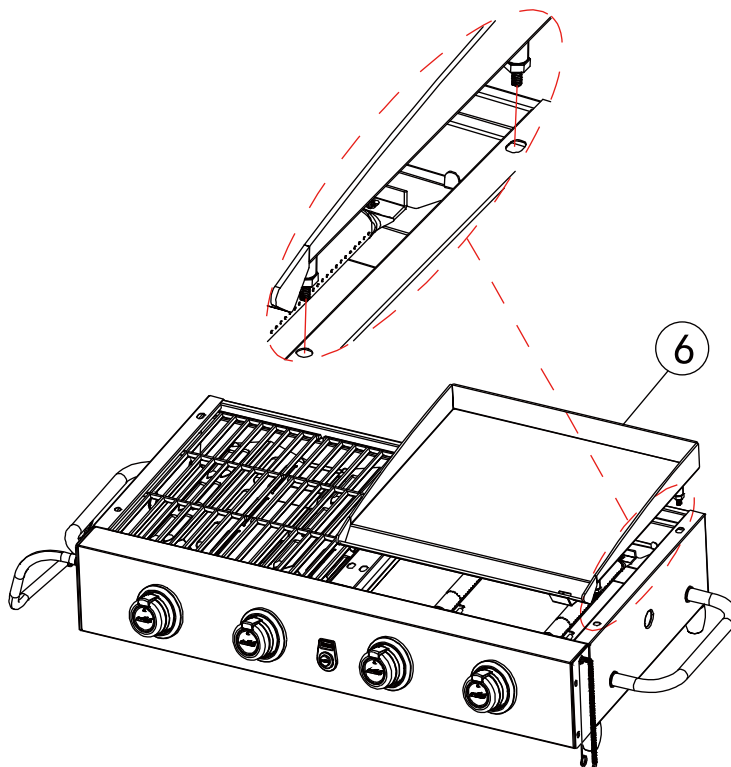

8

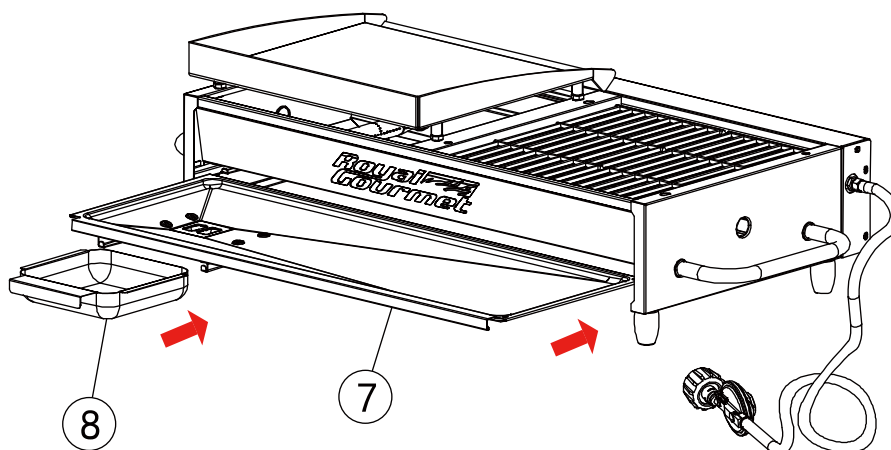

**Thank You  
For Choosing Us.**

**Any Problem!  
We Can Help!**

**Customer  
Service**

**1-800-618-6798**

**Monday to Friday ( 8:30 am - 5:30 pm EST )**

**[service@royalgourmetusa.com](mailto:service@royalgourmetusa.com)**